

CARB-IX

Inline cooling and carbonation package

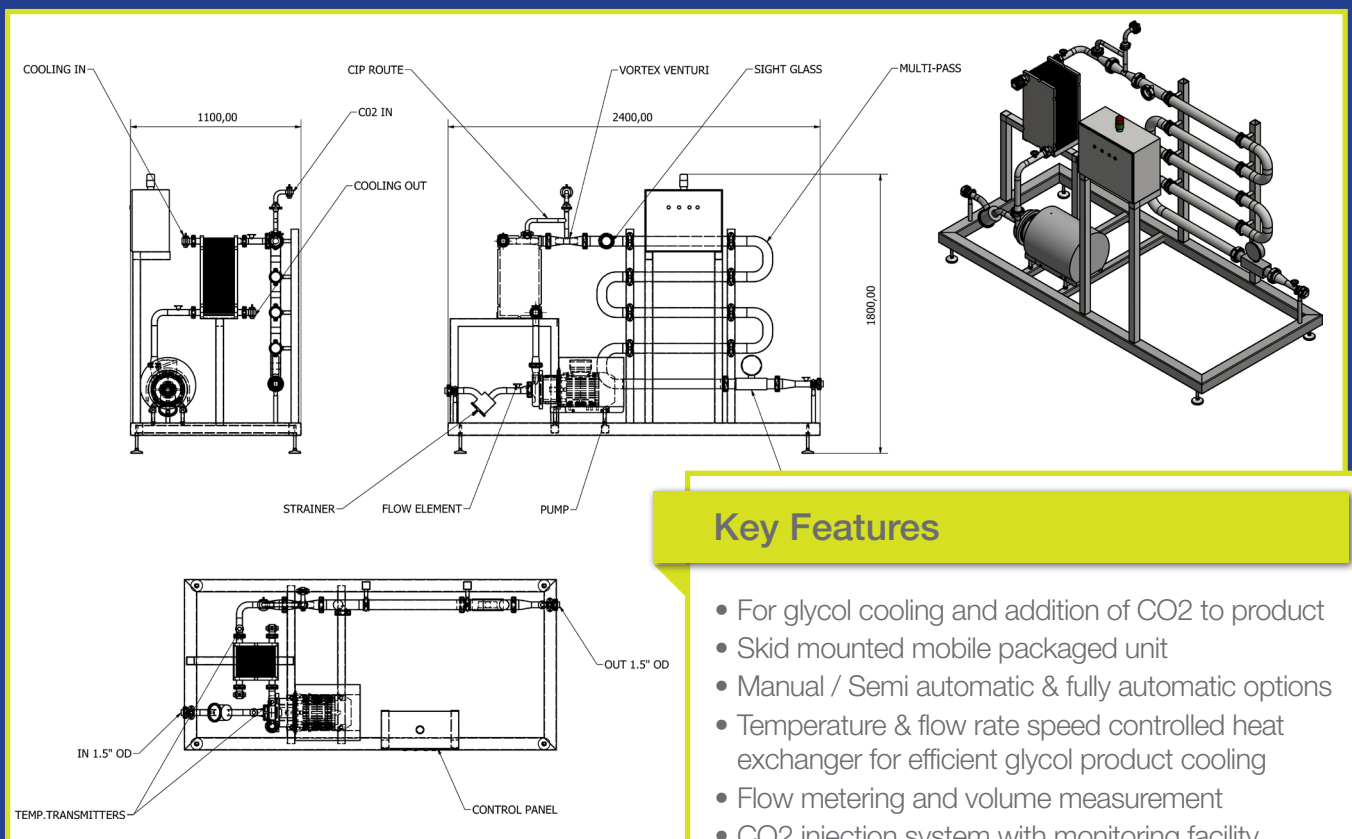

Key Features

- For glycol cooling and addition of CO2 to product
- Skid mounted mobile packaged unit
- Manual / Semi automatic & fully automatic options
- Temperature & flow rate speed controlled heat exchanger for efficient glycol product cooling
- Flow metering and volume measurement
- CO2 injection system with monitoring facility
- Gentle product handling with flexible impellor pump
- Superior protection with run dry control & filtration
- CIP hygiene technology
- Minimal installation on site
- 10 years guarantee (subject to terms & conditions)



Design and manufacture a full range of high quality stainless steel vessels.

As specialists in hygienic vessels, pressure vessels and thermal transfer technology, we custom manufacture to individual requirements. We also offer a comprehensive range of spares.

Product information is for general guidance only and may be altered or amended without notice.